



ENCLOSURES & ASSEMBLY SERVICES

BOX ENCLOSURES, INC
14092 LAMBS LANE
LIBERTYVILLE, IL 60048

TEL: 847-932-4700 WWW.BOXENCLOSURES.COM

FAX: 847-932-4701

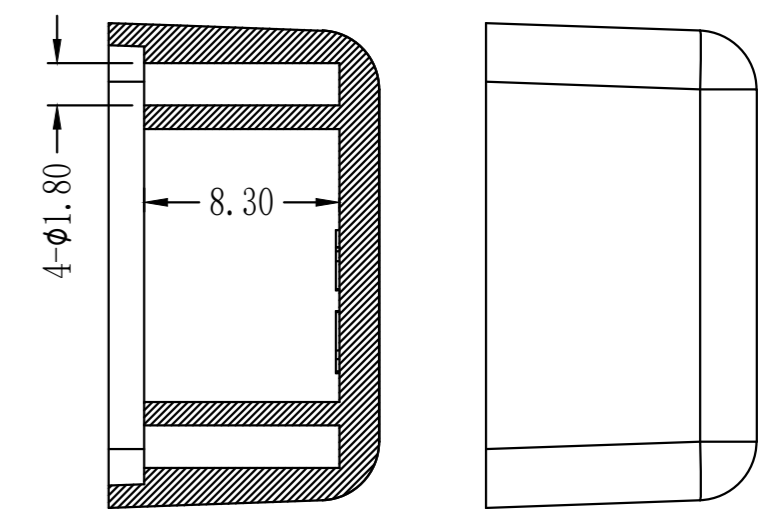
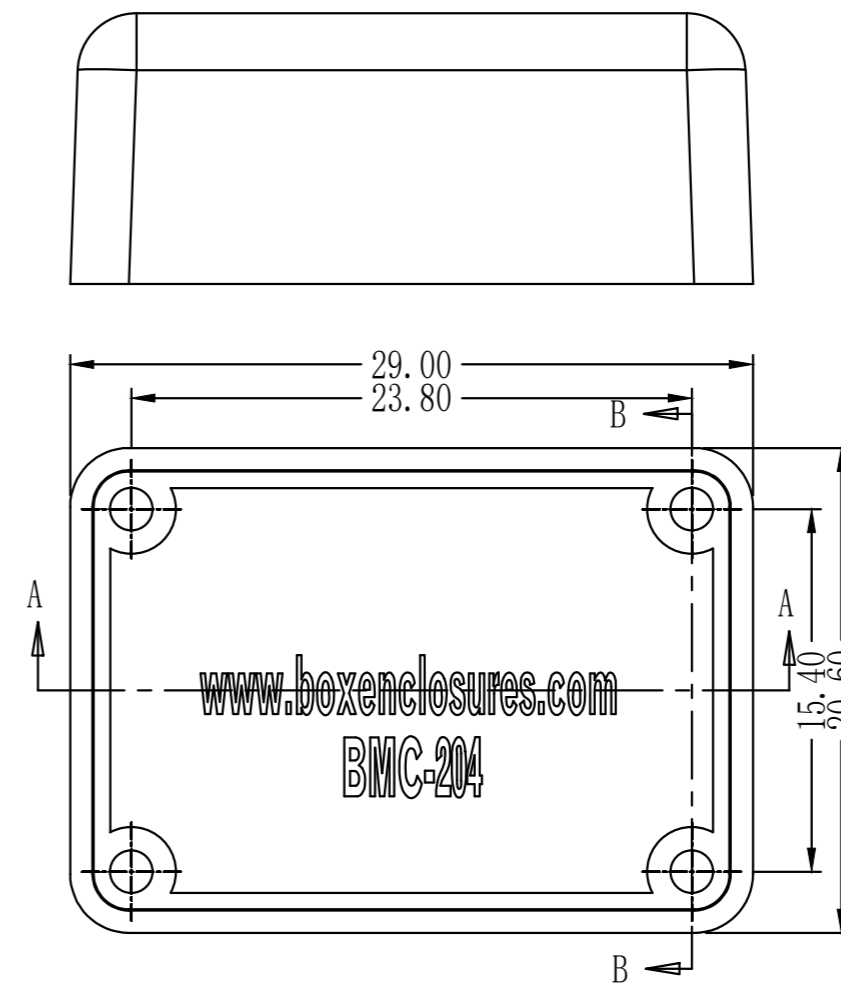
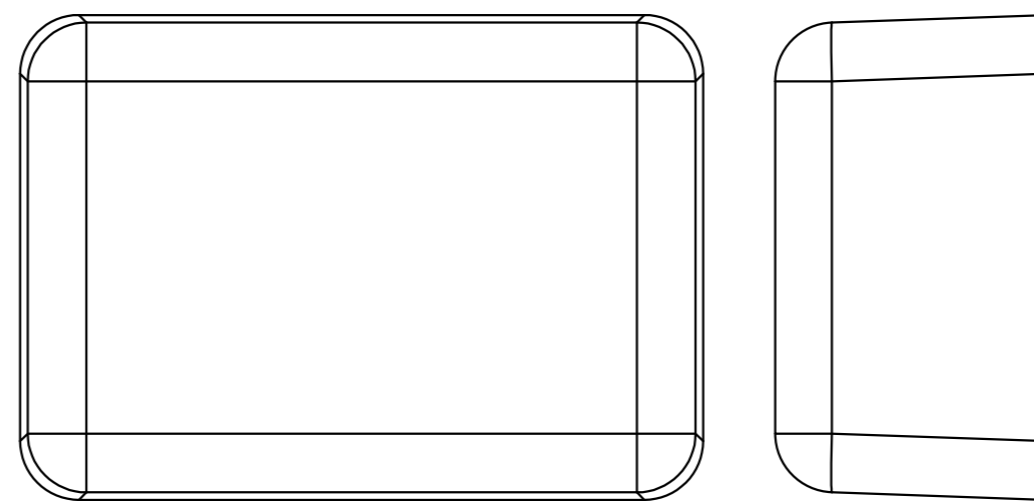
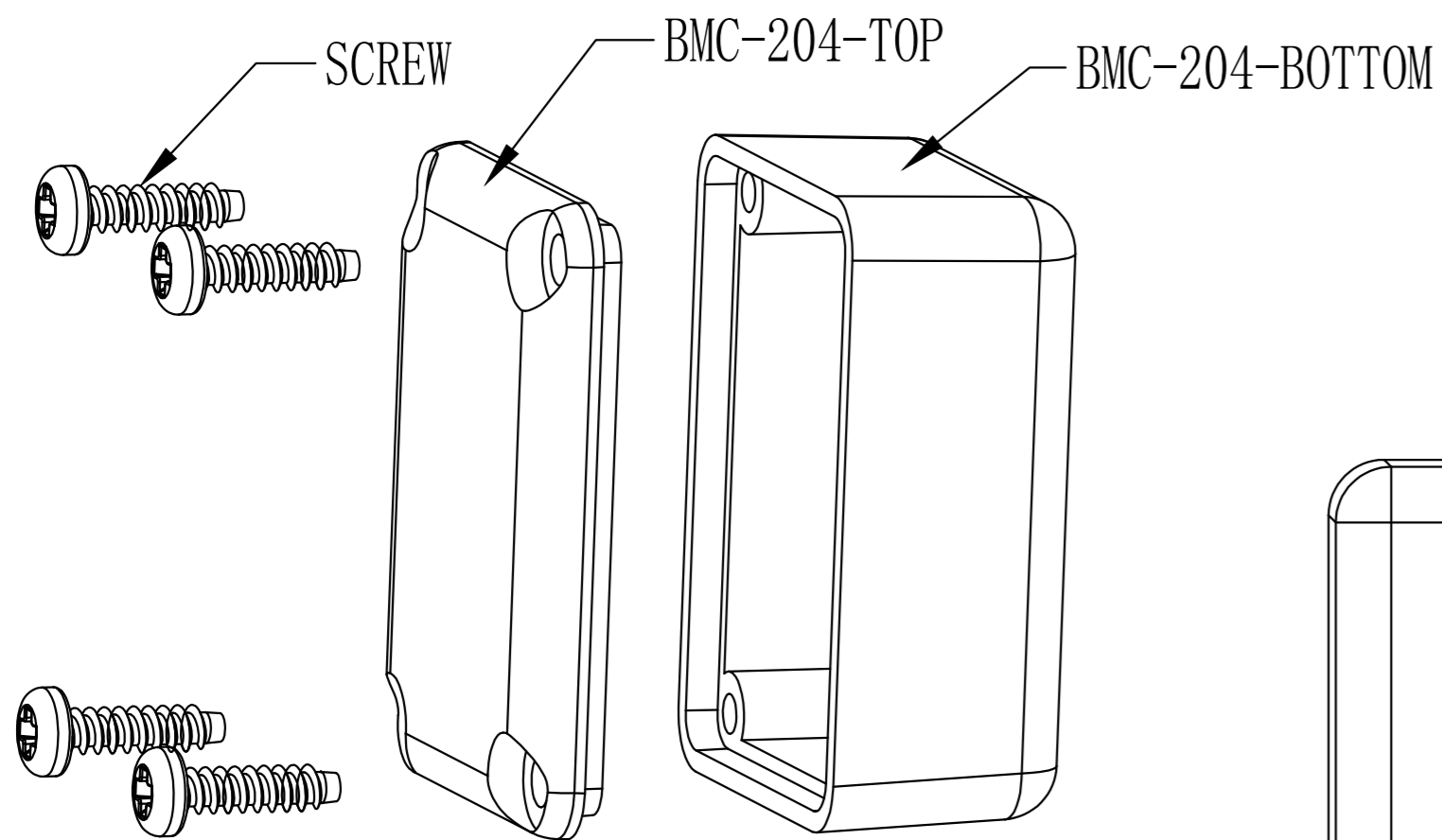

SECTION B-B

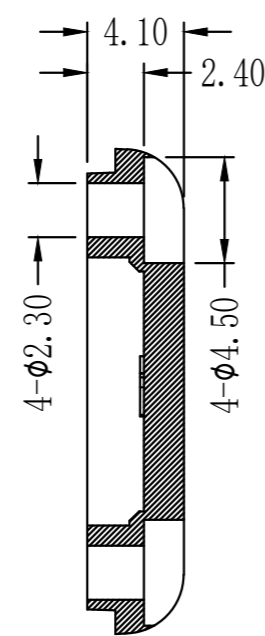
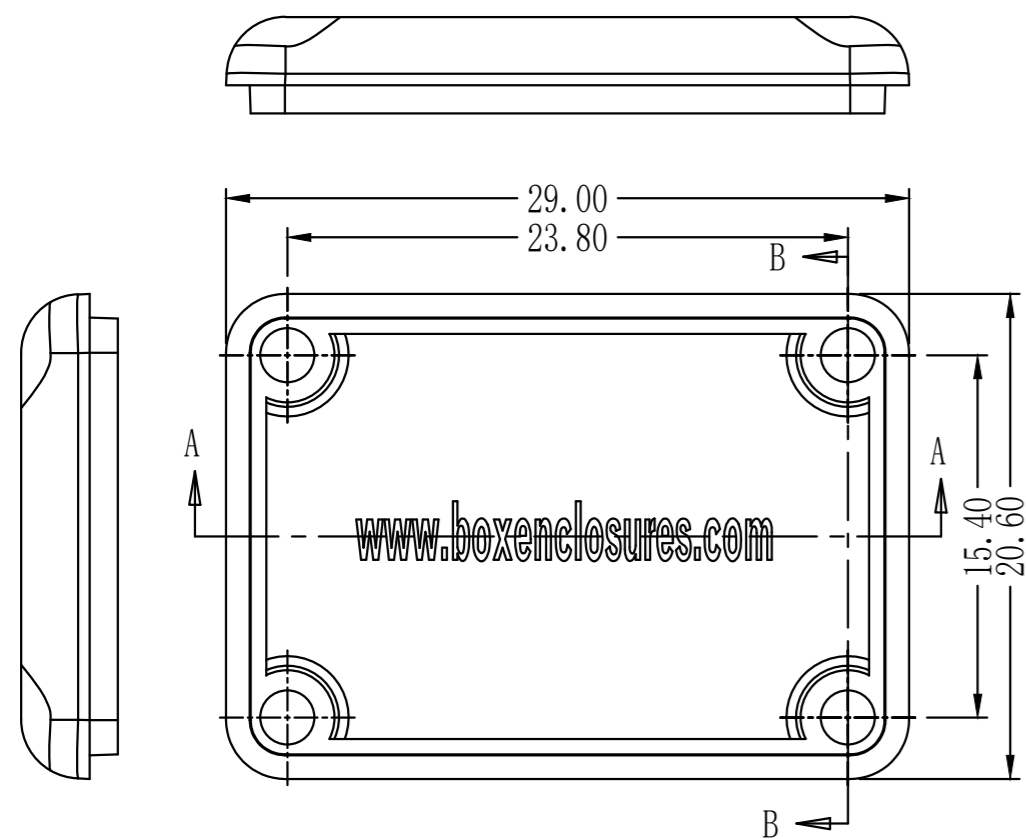

SECTION B-B

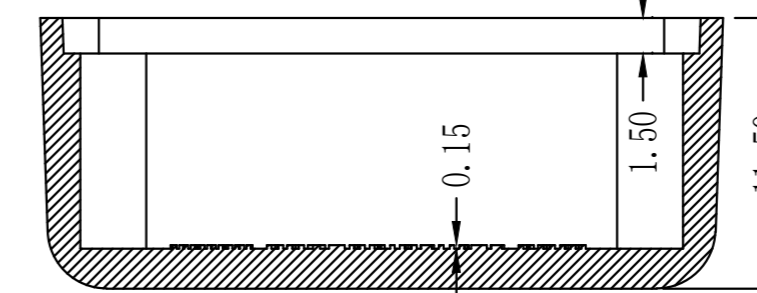

SECTION A-A

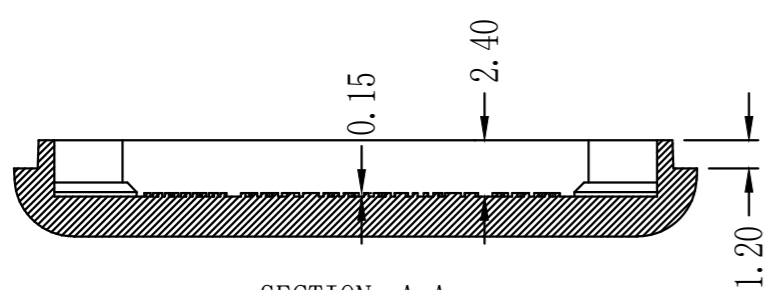

SECTION A-A

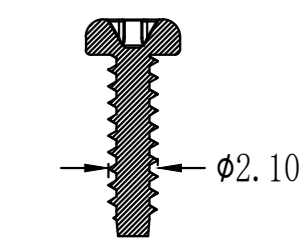
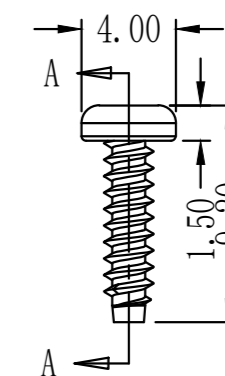
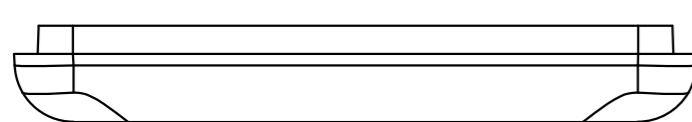

SECTION A-A



ENCLOSURES & ASSEMBLY SERVICES

Title		BMC-204 Master Drawing		Revision:	
Material:		ABS		Model:	
Finish:		TOLERANCE all dimension in mm unless otherwise specified.		Dwg. No.:	
Proj:		x ±0.20 .x ±0.10 .xx ±0.05 ANGLE ±0.5°		Part No.:	
		Color:		Drn. Date 14/1/2010 HUA	
		Qty:		Chk. Date	
		Sheet of		App. Date	

THIS DRAWING IS THE PROPERTY OF AND MAY EMBODY PROPRIETARY INFORMATION OWNED BY Box Enclosures Inc. IT IS PROVIDED UNDER A CONFIDENTIAL RELATIONSHIP FOR A SPECIFIC PURPOSE. THE RECIPIENT AGREES TO USE IT ONLY FOR SUCH PURPOSE AND RETURN IT TO Box Enclosure UPON REQUEST.